

PACTON

Please refer to the load plan sticker at the left front beam of the trailer

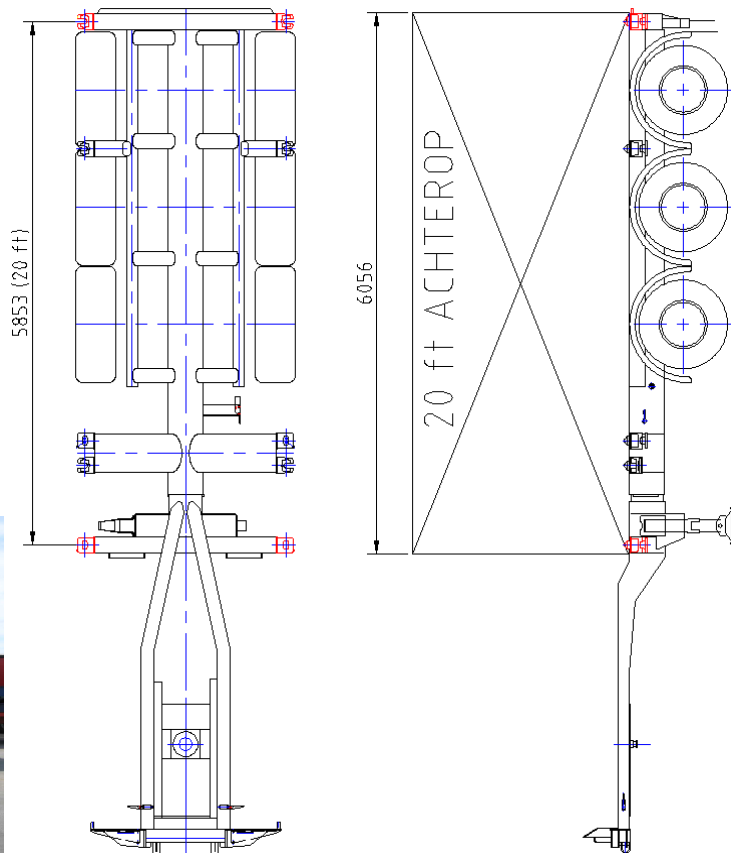

20 FT CONTAINER AT THE BACK



20 FT CONTAINER IN THE MIDDLE

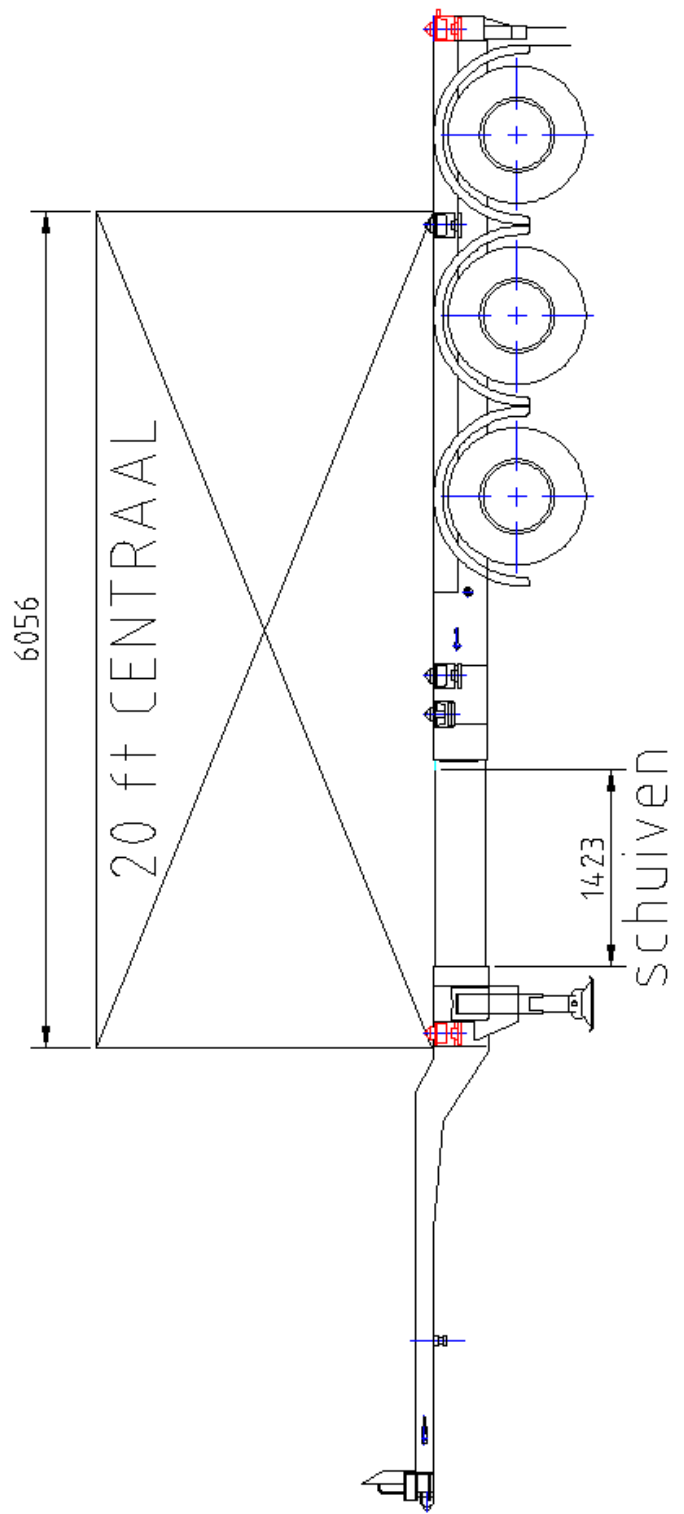
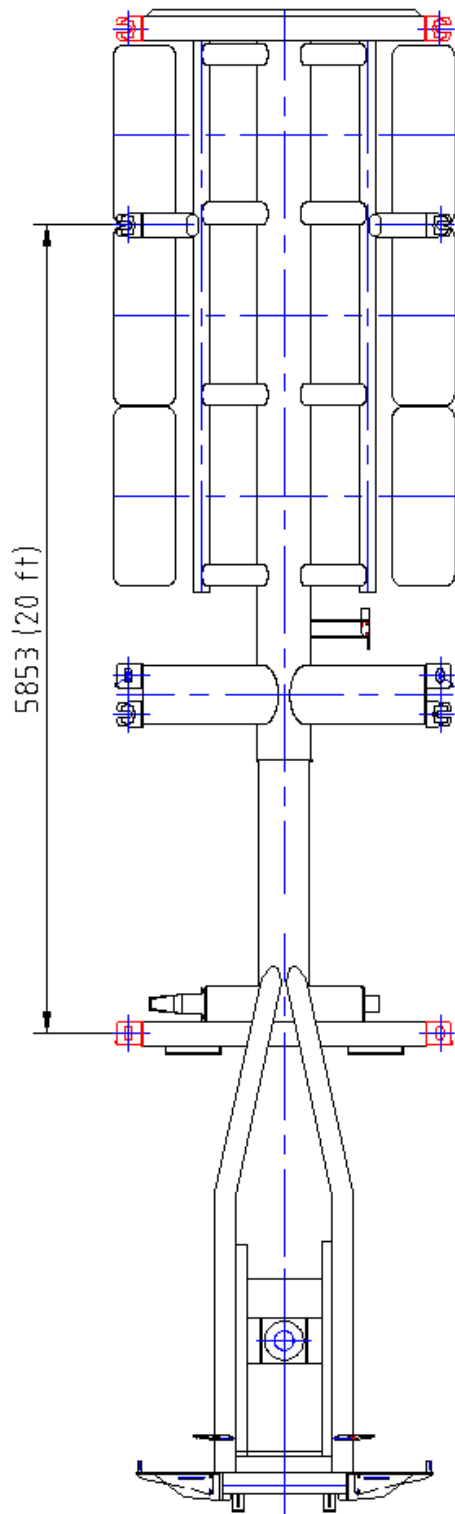

30 FT CONTAINER

Take parts from the front accessoriebox



Install the front containersupport



Install the front containerguides



install the rear lift twistlocks



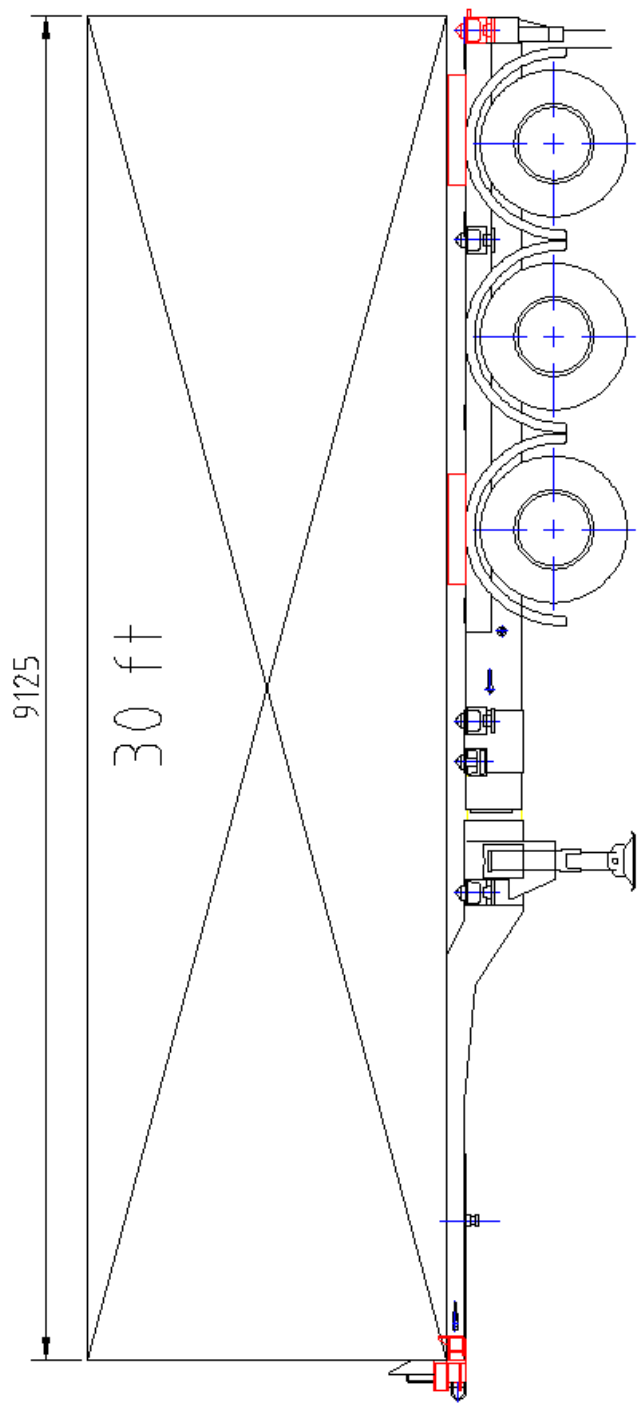
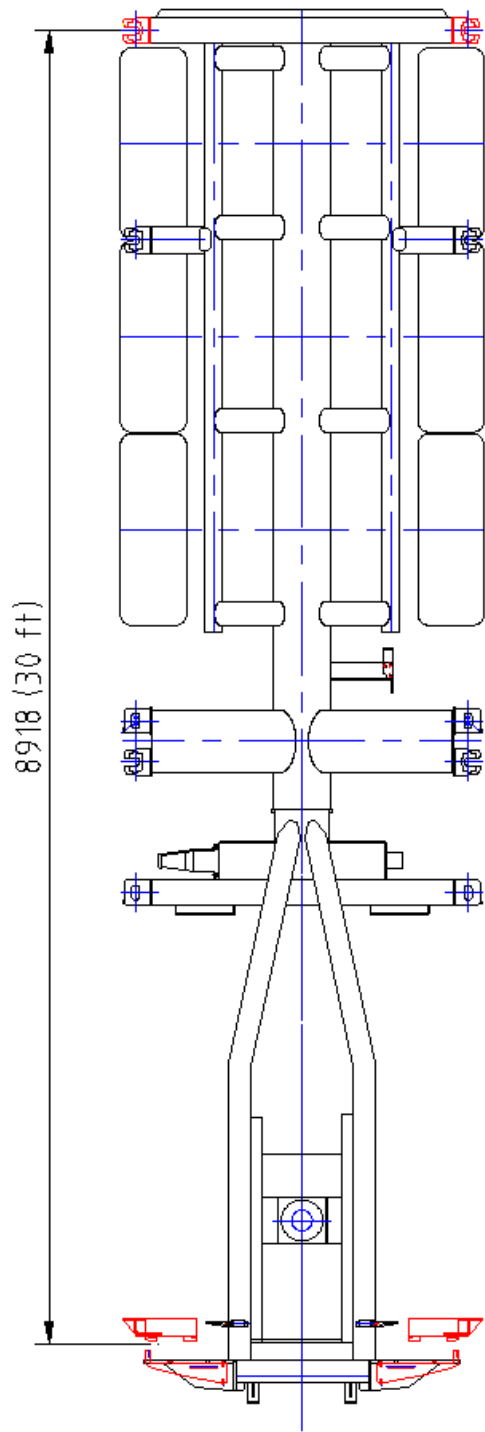

Note: for ease of use and if a lot of on and offloading is done it is easier to extend the chassis to the 40ft position and load the 30ft container behind the gooseneck.

40 FT NON TUNNEL CONTAINER

Take parts from the front accessoriebox



Install the front containersupport



Install the front containerguides



install the rear lift twistlocks



11985 (40 ft)

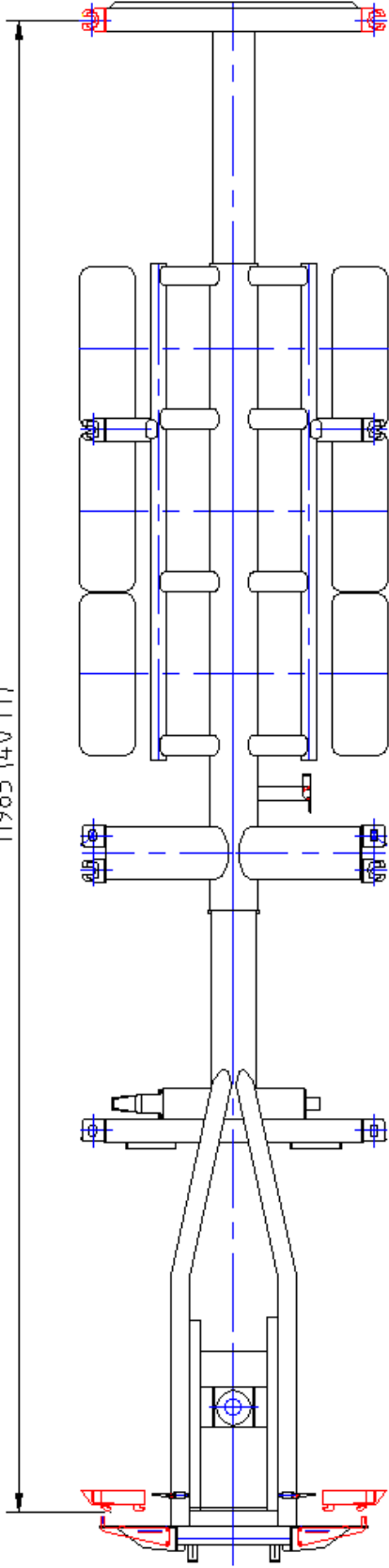

12188

40 ft ZONDER TUNNEL

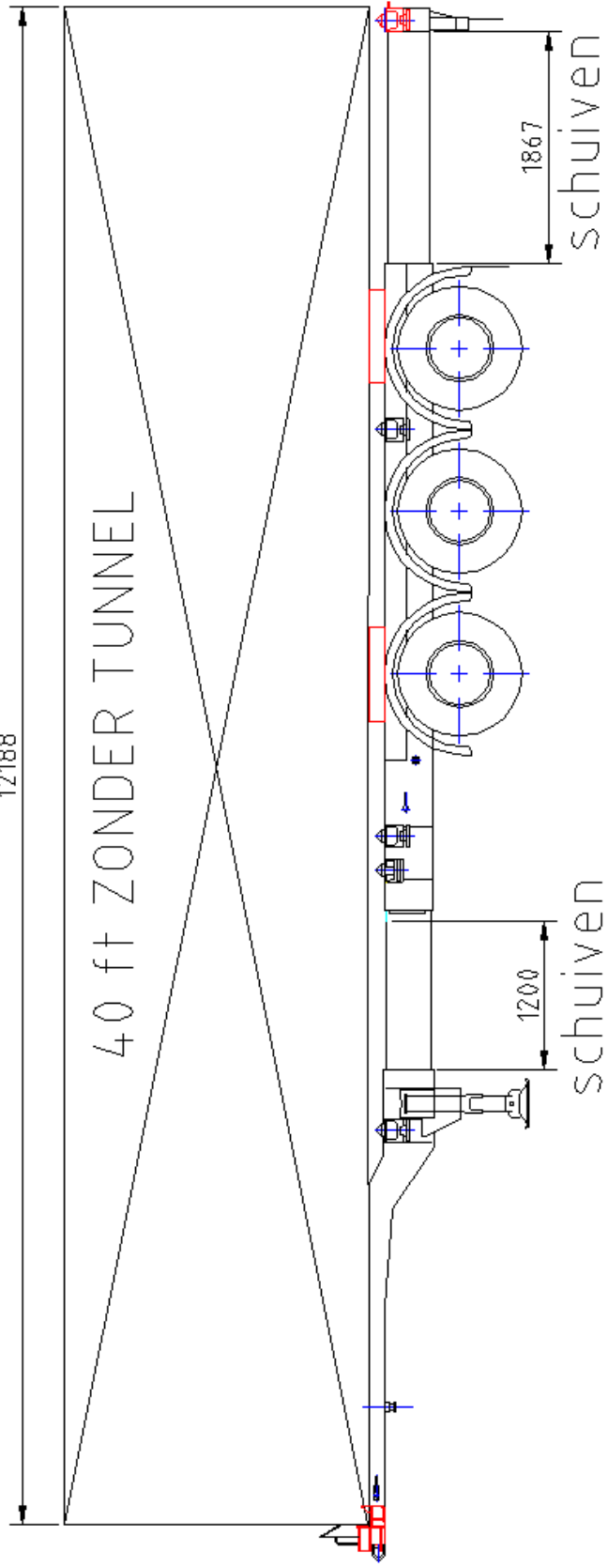

40 FT TUNNEL CONTAINER

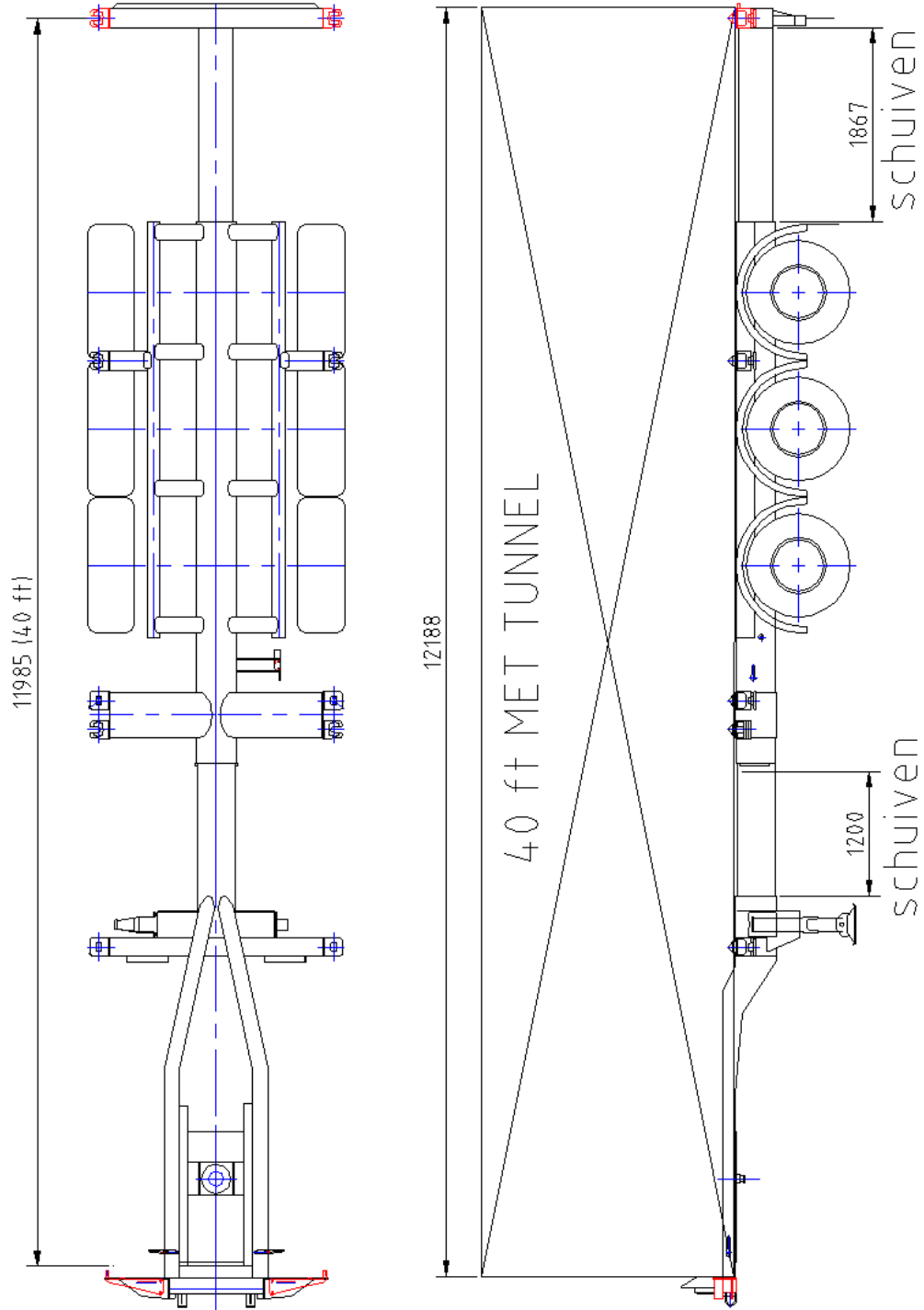

2X20 FT CONTAINER



Take parts from the front accessoriebox



Install the front containersupport



Install the front containerguides



install the lift twistlocks at the front 20 ft position



